

Specifications

Output Power HP (kW)	15 (11)
Phase	3 Phase
Pole	4 Pole
Frame Number	160M

Degrees of Protection	IP 55
Enclosure Construction	Totally-enclosed Fan-cooled
Thermal Class	Class F (155 °C)

Alignment	Horizontal
Frame Material	Cast Iron

Power Transmission	Direct-couple or Belt Driven
Direction of Rotation	Counterclockwise (CCW) viewed from shaft-end side



Connection Type	Lead Wire (6 Leads)
Coating Colour	Munsell N5.5 (Gray)
Conformed Standard	JEC 60034-1 & JEC-2137-2000



Voltage & Frequency	HT Type
	380-415V 50Hz
	380-440V 60Hz (suitable for γ - Δ starting)

* The perpendicular variation of tolerance for the shaft center is $\begin{matrix} 0 \\ -0.5 \end{matrix}$

Dimensions (mm)

Motor												
A	B	C*	D	E	F	G	H	I	J	JK	L	M
252	207	160	324	127	105	20	322	373	55	R6	575	310

Motor		Terminal Box			Shaft End							
N	XB	Z	KG	KD	KL	Q	QK	R	S	T	U	W
260	108	15	127	PF 1 1/4	271	110	90	323	42 k6	8	5	12

Bearing No.		Approximated Weight (kg)	Approximated Packing Dimensions (LxWxH)	Gross Weight (kg)
Drive End	Opposite			
6309ZZ	6308ZZ	107	743 x 601 x 494	128

Connection & Connection Diagram

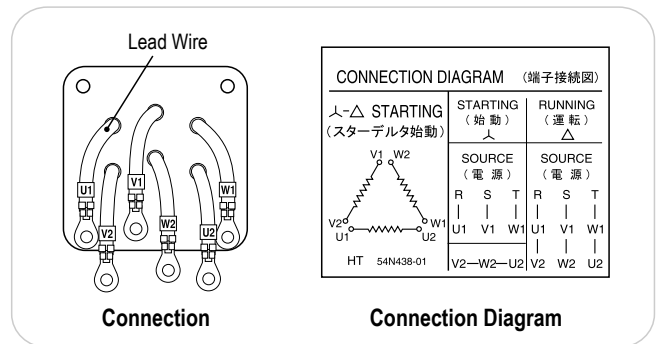

Circumstance Conditions

Ambient Temperature	-20 ~ +40°C
Ambient Humidity	95% RH or less
Operating Altitude	Less than 1,000m above sea level
Environment	No bursting / erosive gas or vapor

Motor Characteristics

Type	Hz	V	50% Load			75% Load			100% Load				Torque(%)		Is (A)	Inertia GD ² (kg-m ²)	
			(A)	Eff(%)	PF(%)	(A)	Eff(%)	PF(%)	(A)	Eff(%)	PF(%)	Speed (r/min)	Torque (kg-m)	Ts			Tm
HT	50	380	12.8	0.90	0.73	16.9	0.91	0.81	21.7	0.91	0.85	1430	7.49	239	245	140	0.26
		415	13.4	0.88	0.65	16.8	0.90	0.76	20.7	0.90	0.82	1440	7.44	287	290	153	
	60	380	11.3	0.90	0.82	15.8	0.91	0.87	20.8	0.90	0.89	1720	6.23	207	212	119	
		440	11.3	0.89	0.72	14.7	0.91	0.81	18.7	0.91	0.85	1740	6.16	283	285	139	